

theben

DIMAX

DIMAX 534 plus 5340001

Installation and
operating instructions
Universal dimmer



310455 02

GB

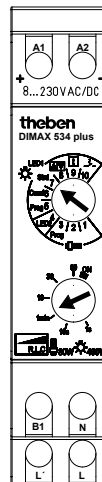

DIMAX 534 plus

Contents

Basic safety instructions	3	– Light scenes with diode module	19
– Designated use		Technical data	20
– Disposal		Service address/hotline	20
Connection/Installation	4		
Functions	8		
– Functions for dimmable compact fluorescent lamps (CFL)	9		
– Function for LEDs	10		
– Functions for standard lamps	10		
Description			
– Dimmer is OFF (Input A1/A2)	14		
– Switch-on brightness	14		
– Minimum brightness	15		
– Wake-up function	15		
– Dimmer is ON (Input A1/A2)	16		
– Snooze function	17		
– Light scenes	18		

Basic safety instructions

GB



WARNING

Danger of death through electric shock or fire!

- Installation should only be carried out by a professional electrician!

- The dimmer is designed for installation on DIN top hat rails (in accordance with EN 60715)

Designated use

- The universal dimmer corresponds to IEC/EN 60669-2-1; it switches and dims the brightness of different light elements such as incandescent lamps, halogen lamps, high-voltage halogen lamps, low-voltage halogen lamps (conventional or with electronic transformer), dimmable compact fluorescent lamps (energy-saving lamps) or dimmable LED lamps for 230 V. The brightness is set via the push buttons connected to the dimmer; use in enclosed areas
- The universal dimmer has a lamp-friendly "soft" on and off system, automatic detection of the load type (not with CFL2 and LED2), overheating protection against overload as well as short-circuit protection

Disposal

Dispose of the dimmer in an environmentally sound manner (electronic waste)

Connection/installation



WARNING

Danger of death through electric shock!

- Must be installed by a professional electrician!
- Disconnect power source!
- Cover or shield any adjacent live components.
- Ensure device cannot be switched on!
- Check power supply is disconnected!
- Earth and short!
- Mount the dimmer in the lower part of the distributor to avoid an excessively high temperature during use.
- With a connected load > 300 W, maintain a distance of 8 mm to the right and left of the device.

Connection/installation

GB



- Electronic and conventional transformers must always be operated at the minimum load specified by the manufacturer.
- Only use dimmable compact fluorescent lamps/LED lamps, normal compact fluorescent lamps/LED lamps could be destroyed.
- When replacing lamps, switch off the voltage supply (at the fuse box) to ensure that the automatic load detection can be reactivated.
- Do not connect dimmer load connections (L') in parallel.
- Do not bypass or short-circuit the dimmer.
- Do not install an isolation or adjustable transformer before the dimmer.
- Do not mix wound and electronic transformers in the installation.
- Do not mix wound transformers and compact fluorescent lamps/LEDs in the installation.
- Do not connect push buttons with glow lamps.
- Correct, automatic load detection is only possible with a connected load.
- Only use transformers approved by the manufacturer for dimmer operation.

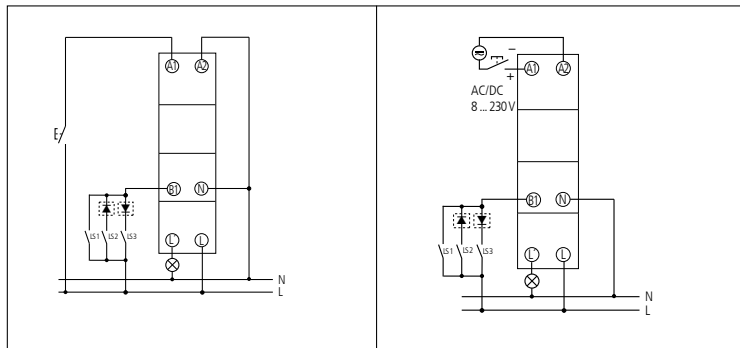

230 V
connection

Connection with
8 ... 230 V

LS 1 = Light scene 1
LS 2 = Light scene 2
LS 3 = Light scene 3

Push buttons A1/A2 On/Off/
Dim

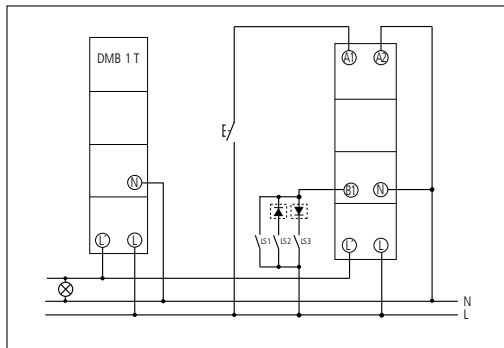

Performance upgrade (see
technical data for DMB 1 T
booster)

Connection with
Booster DMB 1 T (4930279)

Functions

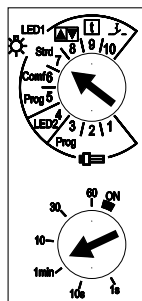

① Rotary switch for setting 10 functions (see P. 13 cont.)

② Potentiometer for setting the dimming time from 1 s to 60 min (for wake-up and snooze function, staircase time switch and switch function)

ON = Dimmer is always on

With some compact fluorescent lamps disruptive flickering may occur when dimming in function 2.

➤ In this case use function 1.

➤ Only change settings with warm compact fluorescent lamps (after approx. 5 minutes).

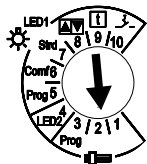

Functions for dimmable compact fluorescent lamps (CFL)

GB

- with adjustable switch-on brightness (preset 100 %)
- with dimming switch-on function
- with wake-up and snooze function
- with light scenes

- 1** With automatic load detection (ideal for lamps from Megaman, Philips); Start always with 100 %, so the CFL go on; Dimming down not possible till after 3 s
- 2** No automatic load detection (always with leading edge) (ideal for lamps from Osram, Philips); Start always with at least 50 %, so the CFL go on; dimming down possible after 2 secs
- 3 Prog** Learn light scenes and minimum brightness (only for CFL) (see P. 15, 18)

Some compact fluorescent lamp types can cause an overload in function 2, which automatically leads to the dimming down of the load

➤ Select function 1 to avoid this.



LED1

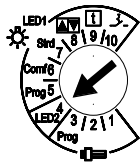

Function for LEDs

4 LED2 Function for LEDs; no automatic load detection (always with leading edge) (ideal for dimming problems with LEDs)

Some LED types can cause an overload in function 4, which automatically leads to the dimming down of the load

➤ Select function 6 or 7 to avoid this.

Functions for standard lamps (e.g. incandescent lamps, halogen lamps, transformer, LEDs)

5 Prog Learn light settings and minimum brightness (see P. 15, 18)

6 Comf Comfort function

- with adjustable switch-on brightness (preset 100 %)
- with dimming switch-on function
- with wake-up and snooze function
- with light scenes function

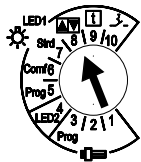

7 Strd Standard function

- with switch-on brightness (preset 100 %)
- with dimming switch-on function
- with light scenes function

GB



8 2-push button function using diode module with double switch or rocker button

- Input B1 = push button input
- with switch-on brightness
- with dimming switch-on function

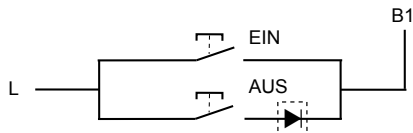

Diode module (9070367)

Push button ON: Switch on/Dim up

Push button off: Switch off/dim down

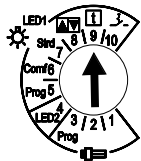

- 9  Staircase time switch function
- Time configurable with potentiometer ⌚ (1 sec – 60 mins)
 - Switch-off pre-warning: After expiry of the set time rapid dimming down to 50 % of the switch-in value. After 10 s slow dimming down to minimum brightness within 30 seconds.
 - Long time function 60 mins:
Activation via long button press
(confirmed by change in brightness)
 - A further keystroke during the expiry time restarts the expiry time (resettable, cannot be prematurely switched off).

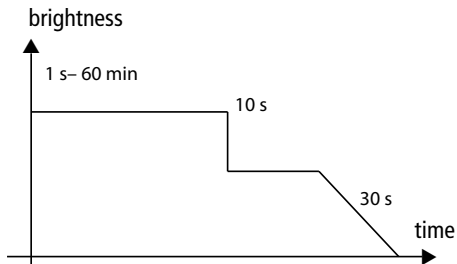



LED1

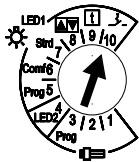

- 10 Switch function (e.g. for presence and motion detector)
– at Input B1: not defined as push button, but as **switch**
Use of the diode module, up to 3 light scenes can be selected here (see P. 18)

Switch ON: slow dimming on; time configurable at potentiometer 2; Set point value with function 5

Switch OFF: slow dimming down; time configurable at potentiometer 2 to minimum brightness, afterwards switch off

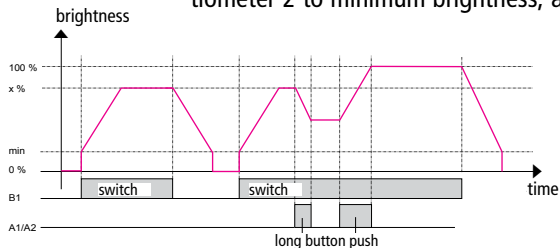

- at push button A1/A2
- with switch-on brightness (preset 100 %)
- with dimming switch-on function
- with wake-up and snooze function

GB

Description

Dimmer is OFF (Push button: Input A1/A2)

–1 x short button press (< 1 s) **Switch-on brightness**
The dimmer starts with the learned switch-on brightness (factory set 100 %)

Teach switch-on brightness

- Set desired switch-on brightness.
- Press push button at Input A1/A2 until a brightness change confirms that it has been learned. Afterwards it is set to the saved switch-on brightness.

–1 x long button press (> 1 s) **Dimming switch-on function**
The dimmer switches on with minimum brightness and dims until the push button is released or the max. brightness is reached.

Minimum brightness

The preset minimum brightness is set in such a way that the lamps still light up.

–Adapting minimum brightness

- Set rotary switch to 5 (to 3 for compact fluorescent lamps). The current minimum brightness is approached.
- Press button at input A1/A2 and dim up or down until the brightness value is achieved.
- Release push button; the brightness value is applied.
- Set rotary switch to desired function again.

Reason: If there is a drop below a specific brightness value, the compact fluorescent lamps/LEDs go off and no longer light up.

Tip: ➤ Switch on compact fluorescent lamp for 5 mins, then set minimum brightness.

–2 x short button press

Wake-up function

Dimmer switch on with minimum brightness, then with the set dimming time is dimmed (Potentiometer ②) to the learned switch-on brightness.

Dimmer is ON (Button: Input A1/A2)

- 1 x short button press (< 1 s) switch off
- 1 x long button press (> 1 s)
 - Dimmer dims up or down
 - Dimming stops at the minimum/maximum value
 - When pushing the push button again the dimming direction is changed
- 1 x long button press (> 10 s) Dimmer dims to the minimum or maximum value.
When the pushbutton is pressed for > 10 s, the previous dimming value (start value) is saved as the switch-on brightness (confirmed by brightness change). Afterwards it is set to the saved switch-on brightness.
- 2 x short button press **Snooze function**
Dimmer dims within the set dimming time (Poti ) to the minimum brightness and switches off.

Wake-up function

Dimmer dims from the minimum brightness to the learned switch-on brightness within the set dimming time.

GB

Snooze function

Dimmer dims from the current dimming value to the minimum brightness within the set dimming time and switches off.

Dimming switch-on function

The dimmer switches on with minimum brightness and dims until the push button is released or the max. brightness is reached.

Light scenes

Up to 3 light scenes can be selected using the push button at input B1. In the case of 2 or 3 light scenes the diode module (9070367) is required.

Activating light scene:

- Briefly press push button at B1.

Learn the light scene using functions 1, 2, 6, 7

- Set brightness value via button at Input A1/A2.
- Press push button B1 (for light scene LS1, LS2, LS3) for longer than 10 s; the value is saved as a light scene (confirmed by the difference in brightness). It is then set to the saved brightness.

Learn light scene with switch B1 at function 10

- Set rotary switch to 5. The current minimum brightness is approached.
- Switch on switch at B1 (close); the light scene is approached.
- Press button at Input A1/A2 to dim up or down.
- Release push button at Input A1/A2 at desired value; the value is changed and applied for the activated light scene.
- Switch off switch B1 (open).
- Set rotary switch to function 10 again.

Several light scenes with diode module (9070367)

Connection with diode module to a dimmer

Light scene 1
preset 50
Light scene 2
preset 25%
Light scene 3
preset 75

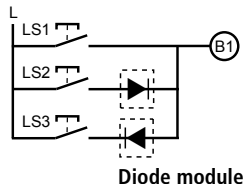

Light scene 1 can also be activated if buttons LS2 and LS3 are pressed simultaneously. This makes it possible to save using push button LS1, if applicable.

Connection with diode module to several dimmers

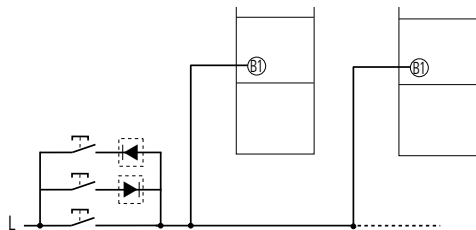

Examples:

Central OFF: Learn all dimmers 0 %.

Central ON: Learn all dimmers 100 %.

Light scene 1: Learn dimmer 1 20 %,
Teach in dimmer 2 70 %, ...

Light scene 2: Learn dimmer 1 50 %, ...
Learn dimmer 2 40 %, ...

Technical data

	Trailing edge	Leading edge
Position of potentiometer	1, 6, 7, 8, 9, 10	2, 4
Operating voltage	230 V~, +10 %/-15 %	
Frequency	50 Hz	
Power consumption	type. 0,3 W	
Standby	type. 0,2 W	
Incandescent and halogen lamp load	400 W (up to 35 °C)* 330 W (up to 50 °C)*	
Dimmable compact fluorescent lamps (CFL)	400 W (up to 35 °C) 330 W (up to 50 °C)	80 W (up to 35 °C) 70 W (up to 50 °C)
Dimmable LEDs	400 W (up to 35 °C) 330 W (up to 50 °C)	60 W (up to 35 °C) 50 W (up to 50 °C)
Electronic transformers (C)	300 W (up to 50 °C)* 330 W (up to 50 °C)*	
Inductive transformers (L)		400 W (up to 35 °C)* 330 W (up to 50 °C)*
Max. line	length 100 m	

Minimum load	none
Permissible ambient temperature	-30 °C ... +50 °C
Protection class	II subject to correct installation
Protection rating	IP 20 in accordance with EN 60529 subject to correct installation

* In the case of a load of > 300 W keep an 8 mm ventilation distance to the right and left.

Service address

Theben AG
 Hohenbergstr. 32
 72401 Haigerloch
 GERMANY
 Phone +49 7474 692-0
 Fax +49 7474 692-150

Hotline
 Phone +49 7474 692-369
 Fax +49 7474 692-207
 hotline@theben.de

Addresses, telephone numbers etc.
www.theben.de